

**PRASAR BHARATI
BROADCASTING CORPORATION OF INDIA
DIRECTORATE GENERAL: ALL INDIA RADIO
(TELECOM DIVISION)**

SPECIFICATION COVER SHEET

TITLE : SPECIFICATION FOR MULTI CHANNEL
STEREO DIGITAL MICROWAVE LINK

SPECIFICATION No. : TC/SPEC/105/2011/Digital MW-LINK

SCHEME : 11th Plan
DATE OF APPROVAL : 18th/May /2011
DATE OF ISSUE : 19th/May/2011
NO OF PAGES : 25
APPROVAL FILE No. : 11/105/STL LINK 35nos./2011-TC

SUMMARY OF CONTENTS:

1. INTRODUCTION :	--	Page No.2
2. SECTION A	: General Specifications/Requirements -	Page No. 3-9
3. SECTION B	: Technical Specifications& Requirement -	Page No. 10- 16
4. SECTION C	: Draft ATP for Digital Microwave Link equipment	Page No. 17- 19
5. SCHEDULE OF REQUIREMENTS	-	Page No. 3-4
6. ANNEXURE –A	LIST OF STATIONS :	Page No. 20-21
7. ANNEXURE –B	Representative Diagram for STL	Page No. 22-23
8. ANNEXURE –C	Typical Stereo Jack Strip Wiring diagram	Page No. 24-25

(M.S. Rawat)
A.E.(TC)

(Baldev Kasturia)
DY. DIRECTOR ENGG. (TC)

**PRASAR BHARATI
BROADCASTING CORPORATION OF INDIA
DIRECTORATE GENERAL: ALL INDIA RADIO
(TELECOM CELL)**

Subject: Specification for the “Multi-Channel Stereo Digital Microwave Link”

INTRODUCTION

AIR requires Multi-Channel Digital Microwave Links for transporting of programs from studio Centre to Transmitter as per list Annexure A. These Microwave links are to be installed using towers (or structures on top of buildings having clear line of sight) at locations as per list Annexure A.

A block diagram showing the Digital Microwave Link set up is enclosed as Annexure-B.

8.	Stereo Wired Racks , Cables, Connectors and accessories	Section. B-8	2 Set/Station (1 set at each end)
9.	Installation and Commissioning of complete link along with provision of proper Earth pits at both Studio and Transmitter end	Section. B-9	1 Job/Station
10.	Training as per tender requirement:	Section A-9	1 Job/Station/Zone
11.	(a) Inspection as per ATP (b) Technical Manual set	Sec. A-8 Sec. A-10	1 Job/station
12.	Details of any other item required for complete integration, commissioning & operation may be furnished with the tender	-----	1 Lot /Station

OPTIONAL ITEMS:

Sl. No.	ITEM	Specification	Quantity
1.	Spares as per list	Sec. A -12	1 set

2. QUANTITY:

Total Quantity and configuration of Multi-Channel Digital Microwave Link at each of the Stations is given, station wise, in Annexure A.

3. LOCATION FOR SUPPLY:

Equipment is to be Supplied, Installed, tested and commissioned at Studios and Transmitter locations at Stations mentioned in Annexure-A.

4. Scope

The scope of this tender includes supply of the equipment as per specifications, technical requirements and quantities as detailed in the tender along with Installation, commissioning and testing (SITC) of the equipments as per mutually accepted ATP at sites as per Annexure-A.

5. Eligibility

The bidder shall have proven experience of carrying out SITC of Microwave Links/Broadcast equipments i.e. Studio, Transmitters, Earth Station etc. Bidders shall provide documentary proof (with attested copies of certificate from client including contact details like Telephone nos. and E-Mail address) of successfully carrying out at least one work of SITC.

Bids without the above valid documents shall be liable for rejection without any further communication.

6. Schedule of Material:

A comprehensive schedule of material offered shall be attached with the offer as mentioned in Section A-1 in the same format as price bid minus the price. Price against each item as indicated in Section A-1(Bill of Material) shall be mentioned separately item wise for mandatory as well as optional items. Make and model of each item must be mentioned.

7. Compliance

The compliance from original equipment manufacturer only will be considered. While complying to the specifications, it may be noted that just mentioning 'complied' will not suffice. Compliance should be supported by proper data/documentation and should substantiate the specifications. In compliance statement each specification item complied, reference of compliance documents page no. etc. should be indicated. Each page of the datasheet/specification shall be duly signed, with seal, by both the OEM and tenderer. The full name, Postal and Telephone contact details including E-Mail address of the person signing on behalf of OEM must be indicated on at least one of the pages. Bids not complying with the above shall be rejected.

8. Inspection: Inspection of the equipment and testing of the installed SITC of the equipment shall be done as per mutually accepted and approved Acceptance Test Procedure (ATP). Draft ATP is annexed.

a) Pre-dispatch Inspection:

Pre-dispatch Inspection of the links shall be carried out at Integrator's works by the Engineer (s) of All India Radio. The expenses towards to and fro journey, DA and lodging will be borne by Prasar Bharati. The performance certificate along with measurements taken on all equipments (duly certified by OEM) is required to be submitted by the tenderer before inspection at their premises.

During the Pre-dispatch inspection, supplier shall put up all the equipments for test on the test bench at integrator premises before the AIR representative and shall provide, electric energy, consumable materials, tools, testing instruments, labour and assistance of required kind for carrying out acceptance tests. All the individual factory test reports of the complete lot of the equipment shall be made available to the inspecting authority before inspection. Complete specifications and details for each equipment will be checked and all parameters/ values will be measured as per ATP. Typical draft ATP are enclosed. Detail ATP shall be submitted by the vender/ OEM and after mutual discussion it shall be approved and inspection shall be carried out on these lines. Three weeks prior intimation for carrying out inspection at Works is to be given by the supplier to the indenter. Inspection charges, if any, are to be quoted separately in the commercial bid.

b) Site Acceptance Test:

After completion of Installation of all the equipments at the Station, Final inspection and testing of the installation at the Station will be carried out by the representatives of AIR for certifying the Installation. This will include visual examination of the installation, overall performance measurements, link level measurements as per ATP and any other measurement/ examination considered necessary by AIR. At least seven working days' prior notice shall be given by the supplier for conducting final Site Acceptance test.

9. Training

The tenderer shall provide two days training to two AIR Engineers on setting up, configuration, operation and maintenance of the equipment at each Station.

In addition to above 5 days training in each zone (Total five zones) for AIR engineers on Operation, Maintenance and Servicing of equipment will be required to be arranged. The expenses on to & fro journey and DA etc. for the trainees will be borne by AIR.

10. Manual/Documentation & Test Certificates:

Manual: [Two each for the station, Two for directorate, one each for Zonal office, one for STI (T) and one for R&D]. Each manual shall consist of following.

a) Manual for operation, configuration, maintenance of each equipment, sub system, NMS, accessories and complete integrated link along with drawings and wiring diagram for the system. (both hard & soft copies)

b) Test procedures for parameters measured at subsystem and integrated system levels.

c) Test records/reports of all the measurements performed for each equipment and integrated system.

11. Delivery Period:

The Delivery Period for SITC and handing over of complete installation for all the sites shall be eight(8) months from the date of A/T.

12. SPARES

Tenderer must quote separately essential spares as recommended by the OEM, including their quantities and cost (per unit). The cost of spares shall not be counted for deciding the commercial ranking of tenders. Various RF modules like transmitter, receiver, interface units, Audio Encoder-Decoder modules, Multiplexer-Demultiplexer modules, Power supply modules, and any item which is to encounter more wear and tear etc must be quoted as spares along with other units.

13. GENERAL REQUIREMENTS

a. Technical/General details

i) The tenderer, in order to enable the indenter to carry out the full technical evaluation of the tender, should give all the details required to ascertain full merits and demerits of the technical offer. Apart from printed technical data/specs of the equipment from the OEM, Block schematic upto the sub-system, interconnection and wiring diagram should be given.

ii) The equipment offered shall be of renowned make, well established and field proven. All the equipments should conform to the power supply and environmental requirement as detailed in para A-14.

iii) The tenderer may be asked to demonstrate the equipment to show compliance to AIR's specification at the technical evaluation stage. The tenderer shall furnish the list of the customers along with contact details (including Telephone No's, E-Mail) where similar equipment has been supplied by the tenderer/manufacturers. In the absence of such list, tender may be rejected.

iv) This equipment shall be of state-of-art technology, capable for 24 Hx365 days operation. It should be incorporated with standard feature of safety and protection.

v) Installation & Commissioning at respective stations shall be carried out without any disruption of AIR/Doordarshan Services. This may require installations at some sites to be carried out even during night hours for which adequate arrangements will have to be made by the supplier at no extra cost to the indenter.

vi) The tenderer shall ensure that the equipment offered fully incorporate the standard features of safety and protection including shielding from EMI/RFI as the receive end of the Link will be installed at high power transmitter site.

vii) Provision of RF cable and associated materials as per site requirement shall be made. The rates of RF cables may be quoted on per meter basis. However, the offer will be ranked on the basis of a notional cable length of 100 meters each at both ends.

viii) Apart from printed technical data/specs of the equipment, Block schematic upto the sub-system, interconnection and wiring diagram, photograph etc. must also be attached with the offer.

ix) Successful bidder may conduct site survey at all the Stations, if felt necessary, to ascertain the conditions at Stations for facilitating installation of indoor equipments, hoisting of Dish antenna on the tower, routing of the cable, length of the RF cable, etc. Minor changes at site, if any, necessitated due to site conditions shall have to be taken care of by the supplier during installation without any extra cost to the indenter.

x) After Acceptance of the tender, the successful tenderer shall also provide detailed plans of supply of material, testing and commissioning as per ATP.

xi) During the installation of these equipment, supplier shall be responsible for safety and security of his material and personnel. At the same time the supplier shall also ensure that there is no damage to AIR material and personnel. The successful tenderer shall make good all damage to the purchaser's buildings, property, equipment, article and departmental personnel arising from the erection of the tower and/or mounting of antenna on tower in the course of such erection or mounting and throughout the guarantee period.

xii) The successful tenderer shall indemnify and hold harmless the purchaser against all claims in respect of damages to buildings, property, articles, situated nearby not belonging to the purchaser, and public personnel arising from the erection of the tower and/or mounting of antenna on tower in the course of such erection or mounting and throughout the guarantee period.

xiii) The successful tenderer shall indemnify and hold harmless the purchaser against claims in respect of injury to any personal howsoever arising from the erection of the tower and/or mounting of antenna on tower in the course of such erection or mounting and throughout the guarantee period.

xiv) The successful tenderer shall fully discharge all obligations under the Indian Workmen's Compensation Act in so far as it affects the workmen under his employment.

xv) The tenderer shall be responsible for safe erection or work on the tower and other accessories etc. The tenderer shall take all necessary safety measures and precautions during the SITC work. The firm shall have to arrange all the installation material required for installation and insure all the personnel climbing the towers at their own cost. Any fixtures, clamps or mounting accessories needed for hoisting the dish on the tower has to be arranged by the firm. Tower work shall be got done at site under the supervision of qualified representative of the firm

xvi) Maintenance support including availability of spares for RF equipment and baseband equipment is to be ensured for at least 10 years from the date of supply. Details of the same should be mentioned in the tender. If at any stage during next ten years the manufacturer proposes to stop production of these equipment and spares, supplier shall intimate AIR in advance to enable AIR to stock the critical items of spares for the life of the equipment

xvii) The tenderer shall mention the source of supply (with proper authorization) for major and critical components/spares so that no difficulty is encountered later on in procuring the spares for maintenance/repair of these equipment.

xviii) All the equipments shall carry a warranty for 12 Months from the date of acceptance of installation at site against any manufacturing defects and failures.

xix) All optional items mentioned in the tender must be quoted. Failing this, the tender would be liable to be rejected. However, these items would not be considered for ranking purpose.

xx) The tenderer/firm must have a well equipped & established service center in India. The complete address and contact details of the Service centers in India, duly certified by the OEM, shall be indicated. The firm/tenderer must ensure repairs within 72 hours at site & in case the equipment can not be repaired at site then the firm shall bear all the charges including to & fro freight charges to repair the equipment within or outside the country during the warranty period.

For all equipments after sales service is to be ensured for post warranty period also for 10 years.

14. Environmental & power supply

a) Ambient Temperature (for outdoor units) :

-30°C to + 40°C – For Srinagar (Hill Stations)

-10°C to + 50°C –For other Stations

b) Relative Humidity : Upto 95% non condensing at 40°C

c) Safety/features : Standard features for safety & protection have to be built in /incorporated for both personnel/equipment.

d) Power supply : 230VAC±10%, single phase, 48-52 Hz.

SECTION-B

TECHINCAL SPECIFICATIONS FOR MULTI-CHANNEL DIGITAL STEREO MICROWAVE LINK

1. TRANS-RECEIVE EQUIPMENT

Trans-Receive equipment housed in a chassis should be supplied in 1+1 hot standby configuration. Transmitter section of this RF equipment should be capable of receiving E1 data from the Audio baseband equipment and the receive section should be capable of retrieving the E1 data from the RF receiver and feed it into Audio baseband equipment for facilitating demultiplexing of the Audio.

KEY FEATURES:

1. Full duplex operation.
2. Should be capable of delivering E1 data.
3. 19 inch rack mounting.
4. Each Trans-Receive unit should be capable of working independently in case of failure of Auto-Change over switch. All connectors and cables required for independent operation of standalone Trans-Receive unit shall be supplied.

TX/RX System:

1	a) Frequency of operation: b) Step Size: c) RF Frequency Stability: d)Tx-Rx Spacing:	1427-1525 MHz, Fully Synthesized, tunable Less than 1MHz. Better than or Equal to 3 PPM. It should be possible to Transmit and Receive simultaneously frequencies spaced 49MHz apart
2	Modulation/Demodulation	32 QAM
3.	RF Bandwidth	≤500KHz
4.	Data Rates:	1E1.
5.	Interfaces: a) Data: b) Service Channel: c) Order wire:	G.703 RS232 @9600bps. Voice handset interface along with handset.
6.	Forward Error correction	Reed Solomon
7.	RF O/P power at (1+0 mode)	≥30dBm at 50 ohms
8.	Spurious and Harmonics Emission	< - 60 dBc
9.	Receiver Sensitivity (for 10 ⁻⁶ BER)	Better than –88dBm

10.	Dynamic Range	Better than 40 dB
11.	(a) Configuration: (b) Insertion loss for change over unit of (1+1) mode	(1+1) Hot standby with auto changeover. Also should work in 1+0 mode (Change over switch bypass mode) Tx \leq 2 dB Rx \leq 5 dB
12.	Power Supply	230 VAC \pm 10%, 50 Hz \pm 2 Hz
13.	Standard Compliance:	ETS /EN international Standards for EMC/EMI and Radio Performance.
14.	Size	19" Rack mount.

2. AUDIO BASEBAND UNIT

I. Baseband unit with relevant cards and accessories for 3 audio stereo channels.

The audio base-band Unit should be a separate unit & not an integral part of the RF equipment. The system should be offered as **(1+1)** chassis frame housing Power supply card in 1+1 redundant mode and relevant cards required to meet specifications for three audio channels (with individual card for each audio channel) and other specs. (Detail of cards be furnished by tenderer)

E1 Base band unit should fulfill the following features. The unit should be ITU-T G.703 complaint and it is to interface with E1 circuits which are being provided by MTNL/BSNL or Microwave link Trans-Receive equipment (specified –Section B-Item 1).

1. Baseband equipment should be able to transport audio channels with analog & digital input/outputs, up to three nos, each occupying data rate from 64kbps to 384 Kbps per channel(in 64 kbps increments) in simplex mode.
2. Baseband equipment should be able to transport IP data stream upto \geq 1.2Mbps in duplex mode, multiplexed with the coded audio data over E1. It should be possible to allot time slot for this stream statically and/or dynamically.
3. Transportation of NMS control data for control, monitoring etc. of remotely placed equipments i.e. Baseband, RF and UPS equipment etc. to other side and vice-versa. Provision is to be made for multiplexing it over E1.

4. The system should be designed for continuous 24 Hours operation and should be software upgradable.
5. NMS is to be SNMP based with features as detailed Sec. B-7.
6. It should have Status display by LED's or other visual form and audio alarm in case of failure.

1.	Input/output	Analog and Digital (AES/ EBU), IP data stream, NMS control data, Auxiliary data
2.	Audio Channels 3 No., Mode	Mono, Dual Mono, Stereo
3.	Aggregate Throughput Rate	E1
4.	Frequency Response	Within +/-1 dB for 30 Hz to 15 KHz w.r.t 1Khz at nominal level
5.	Audio input level (nominal at 1 KHz)	0dBu
6.	Audio input level (Max. at 1 KHz)	18 dBu above nominal
7.	Input Impedance (For Analog)	600 Ω Balanced / ≥ 10 K Ω (user Selectable)
8.	Audio output level (nominal at 1 KHz)	0dBu
9.	Audio output level (Max. at 1 KHz)	18 dBu above nominal
10.	Output Impedance (For Analog)	600 Ω / ≤ 100 Ω (user Selectable)
11.	Input / Output Impedance (For Digital Audio)	110 Ω
12.	Input / Output connectors	XLR In case the connectors on the encoder/decoder module are different from XLR, suitable adopters for terminating audio input/output on XLR connectors shall be provided and all XLR connectors shall be terminated on a back panel in the rack at no extra cost to the indentor.
13.	Coding Algorithm	MPEG 1 Layer II
14.	A to D Conversion	24 Bit

15.	Sampling Frequency	48 KHz
16.	THD (1 KHz at max output level)	Less than 0.1%
17.	Cross talk	Better than 80 dB
18.	SNR	Better than 85 dB
19.	Audio coded data rate	Configurable 64, 128,192, 256,384 kbps per channel
20.	Auxiliary Data channel	One, upto 9.6 kbps, Serial RS 232 duplex mode.
21.	Mounting	19" Rack
22.	Jitter Tolerance	Shall Conform to CCITT Standard
23.	M&C interfaces	Serial RS232 Asynchronous, Ethernet 10Base-T

All parameters of audio performance detailed above are to be measured with encoder –decoder in chain with at least 256kbps data rate.

3. **ANTENNA (TRANSMIT/RECEIVE) ALONG WITH FEED**

Antenna should be of reputed make and should be fully compatible with RF part of the link. All the parts of the antenna such as mounting fixtures etc. must be of same make and should be the part of the antenna kit from the same manufacturer. Antenna should be supplied with Radome arrangements for installation at AIR Srinagar.

1.	Diameter (nominal)	1.8 M (around)
2.	Gain (dBi) (midband)	≥ 26dBi
3.	Front to back ratio (dB)	≥ 30
4.	Polarization (mono-polar)	Linear adjustable (Vertical or Horizontal)
5.	Impedance	50 ohm (N.connector)
6.	Type i. For 34 stations ii. For Srinagar	Grid pack/Flat panel Solid parabolic with Radome
7.	a) Weight (including mounting fixture) b) For Srinagar solid parabolic dish with Radome etc.	≤ 50 kg ≤ 85 kg
8.	Azimuth adjustment (degree)	Min ±45 degree
9.	Elevation, adjustment (degree)	Min ± 5 degree
10.	Wind velocity (Survival)	180 Kmph
11.	VSWR	≤ 1.25

4. RF Cable

1.	R.F. cable loss at 1.5 Ghz	≤ 5 dB per 100 Meters
2.	R.F. cable impedance	50 +/- 1 Ohms

Cable should be provided with all installation and earthing kit. This Cable is to be earthed at Equipment rack, at Antenna end and in between along the length of the tower.

5. **2KVA UPS (Rack Mount Version) in (1+1) Parallel Redundant Load sharing Configuration:**

2KVA Rack mountable shall be supplied in (1+1) parallel configuration. Each such unit (i.e. 2KVA UPS in 1+1 parallel configuration) shall be required to be supplied at Studio end as well as at Transmitter end.

1.	Type	On line, pure sine wave
2.	Power rating	1400W/2 KVA, Single phase
3.	Configuration	(1+1)Parallel Redundant load sharing mode
4.	Output Bus bar	The output of both the UPS's will be connected to a single bus bar. Normally when both UPS's are OK they shall share 50:50 loads. In case of failure of any of the UPS, full load will be taken over by other unit.
5.	Battery back up	For 30 minutes operation on full load
6.	Type of Battery	Sealed Maintenance free battery. Separate Battery pack has to be provided for individual UPS. (Batteries need not be Rack Mounted)
7.	Input voltage range	230±20% V A/C (at full load)
8.	Input frequency range	50 ± 5% Hz
9.	Output Voltage	220V, 50 Hz, Single phase
10.	Output Voltage regulation	+/- 2%
11.	Output frequency	50 Hz
12.	Type of approval	ISO certified, standard, reputed make
13.	Metering & indicators	It should be possible to monitor battery low, over Load etc. through Meters/Indicators & Network Management Software (NMS). It should also be possible to monitor all types of alarms.
14	Maintenance Bypass	Suitable circuit breakers be provided to facilitate removal of defective or installation of repaired UPS without affecting normal operation at load side.

6. WORK STATION FOR NETWORK MANAGEMENT SYSTEM (NMS):

Reputed make Laptop/Notebook computer along with a laser jet printer shall be provided individually at both Studio and Transmitter end. It should be mounted in the rack with slide in provision.

The laptop should be loaded with the latest operating system i.e. Window Vista etc. licensed in the name of consignee. Recovery CD media including all driver is also to be provided.

Laptop/Notebook computer shall be loaded with NMS from Original Equipment Manufacturer (OEM) for both R.F. Trans Receive equipment and Audio Base-band equipments as indicated in Bill of Material.

7. NMS features:-

The NMS (with license) must be using the industry standards SNMP as the underlying framework for managing network devices, providing a simple, intuitive suite of tools to configure network elements, monitor performance, detect and correct faults quickly.

It should allow remote performance monitoring, fault management, BER measurements, Security management, configuration and control of MW link equipment and Audio Baseband equipment,

- Network diagnostics for MW Link
- Proactive alarm/fault notification
- Remote network configuration
- Based on industry standard SNMP easy to integrate
- Graphical and Tabular displays-simple to use
- Event log upload and viewer

The NMS should be capable of monitoring the status, controlling and setting operational parameters of R.F. Trans Receive equipment and Audio Base-band equipments. NMS should be also capable of configuring and monitoring receive side RF and Baseband equipment from transmit side itself and Vice versa. Any hardware keys (dongle), if required, for operation of NMS shall be supplied at each end.

8. WIRED RACKS FOR EQUIPMENT

All the above indoor equipment shall be installed in the full size, 16 SWG wired rack of height 42U and overall depth of not more than 800 mm along with requisite jack- strip, Tag block & other items both at transmitting and receiving site.

Audio distribution Amplifier (Analog & Digital) inputs and outputs shall be wired. It is to feed Audio to input of normal and standby Encoder and to the switcher of monitoring Amplifier input at studio site. At transmitter and studio site monitoring amplifier input is to be wired as shown in block diagram (Audio distribution and Monitoring amplifier shall be provided by the I O of zonal office). All channels input at studio site and output at transmitter site are required to be wired as detailed tentatively in Annexure ' C.'

The rack must be properly fitted, grouted and earthed. The rack shall be powder coated as per six tank process with air ventilation. It shall be fitted with cooling fan, light, power distribution board with proper RFI and EMI fitters. The jack strip, Tag block, cables and connectors used must be of highest professional quality. All these items shall be of reputed brand. The brand offered shall be mentioned in the bid (Ordinary cables and connectors shall not be accepted).

Typical stereo Patch panel configuration for a 2+2 audio channel configuration system is shown at Annexure-'C'. For other audio channel configurations similar wiring has to be adopted. Successful tenderer will be required to submit detailed rack wiring diagram within 15 days of placement of order to this Directorate for approval.

9. INSTALLATION & COMMISSIONING

Installation will include installation of all the equipments within the wired racks, hoisting of the dish antenna over the towers or the roof top steel structure, routing of the RF cable from the antenna to indoor system, earthing of RF cable at either end and in between along the length of tower, and providing earth pits as per AIR Specifications(Earth resistance <1ohm) at both the Studio and Transmitter end at each of the Station. Racks and all the equipment must be earthed. The workmanship of the entire Installations shall be of highest professional standard.

Installation schedule at Stations has to be intimated at least 3 weeks in advance. Complete Installation at each station shall thereafter be offered for Site Acceptance Test and Inspection at site shall be conducted by the representatives of DG: AIR.

SECTION C
DRAFT ATP FOR DIGITAL MICROWAVE LINK

1. INTRODUCTION

This document describes the Acceptance Test Procedure (ATP) for testing the various units of the Digital Microwave Link Equipment under procurement. It covers the details of the item to be tested, list of equipment required for testing and the tests required to be carried out.

2. ITEMS TO BE TESTED

The items to be tested first individually and then integrated are as follows:-

a) Individual Items

- i) R.F. Tran receive Equipment
- ii) Base Band Unit
- iii) Other peripheral equipment such as Computer & UPS etc.
- iv) NMS

b) Integrated Setup

Complete integrated setup from Audio input to base-band unit to audio output from base band unit

3. TEST EQUIPMENT

- a. All requisite test equipment conforming to the required standard for testing and commissioning shall have to be provided by the supplier.
- b. Indicative List of the test & measuring equipment:

- i) Spectrum Analyzer (>2 GHz range)
- ii) Power Meter with sensor & Attenuator etc.
- iii) Frequency counter
- iv) Signal Generator
- v) Audio Analyzer
- vi) BER Tester
- vii) Digital Modulation Analyzer having Digital demodulation feature.
- viii) PC with Printer
- ix) Directional Coupler, inter-connecting cables, attenuators, combiners, Dividers, etc. as may be necessary for the tests.
- x) Any other equipment and standard reference source/setup necessary for measurements.

4. TESTS REQUIRED TO BE CARRIED

(NOTE: This is only a tentative list, additional items of tests may be specified by the indenter, if needed.).

4.1 RF TRANS-RECEIVER

- i) Functionality test for individual RF Trans-Receiver and in (1+1) configuration
- i) Power output check
- ii) Frequency stability and accuracy
- iii) Spurious & Harmonics
- iv) DATA rate & coding standards
- v) Digital modulation
- vi) Any other tests to check the conformity to the specs.

4.2 Audio Base band Unit

- a) Functionality test for individual Base-Band unit
- b) Coding standard, data rates check
- c) All Base-band measurements i.e. Frequency response, THD Noise level, Cross talk etc. as mentioned in ATP.

4.3 RECEIVER

- ii) Functionality check for individual monitoring setups for Analog signal and Digital signal
- iii) Tests for Analog output receiver including sensitivity, carrier lock range, audio output level: THD, Noise level, frequency response, cross talk etc.
- iv) Test for Digital O/P receiver including, carrier lock range, BER, Eb/No, Audio output, level, THD, Noise Level, frequency response, cross talk for both stereo channels, BER immunity test etc.

4.4 INTEGRATED SETUP

- i) After the individual tests the equipment will be installed and integrated to Work as MW link as per specs. The integrated setup will then be tested for complete system performance and functions.
- ii) The tests for commissioning would include the integration check and Conformity to system specs. including
 - a. EIRP
 - b. Radiation conformity to standard specified
 - c. Emissions conforming to international standard. Overall Performance measurements to meet the specs.
 - d. Cable Loss(both at Transmitting & Receiving end)
 - e. Alignment of dish for optimum performance

4.5 PERIPHERAL EQUIPMENT

All peripheral equipment shall be tested for the various functionality prescribed and conformity with these specifications.

4.6 In addition all the manuals/drawings will be inspected for completeness.

5. GENERAL

i) Based on above supplier is required to give a detailed ATP document giving procedure for tests of individual item as well integrated setup. This should include test setup, equipment details, inter-connection diagram and the format for test reports.

ii) The indenter will examine the same and then it will be finalized after mutual discussion.

LIST OF STATIONS FOR STUDIO TO TRANSMITTER CONNECTIVITY

NORTH EAST ZONE

Sr.no	State/station	FROM	TO
1.	NAGALAND KOHIMA	STUDIO	TX
2.	TRIPURA KAILASHAR	STUDIO	TX
3.	MEGHALAYA SHILLONG	STUDIO	FM TX

EAST ZONE

Sr.no	State/station	FROM	TO
1.	WEST BENGAL SILIGURI	STUDIO	TX
2.	BIHAR PATNA	STUDIO	HPT
3.	BHAGALPUR	STUDIO	FM TX

SOUTH ZONE

Sr.no	State/station	FROM	TO
1.	TAMILNADU COIMBATORE	STUDIO	FM TX
2.	TUTICORIN	STUDIO	TX
3.	ANDHRA PRADESH ANANTPUR	STUDIO	TX
4.	KERALA THIRUVANTPURAM	STUDIO	FM TX
5.	TIRUPATI	STUDIO	REPEATER(DOT TOWER)
6.	TIRUPATI	REPEATE	FM TX

		R	
7.	VISHAKAPATNAM	STUDIO	TX
8.	PORTBLAIR	STUDIO	TX
9.	PONDICHERY	STUDIO	TX

WEST ZONE

Sr.no	State/station	FROM	TO
1.	MAHARASHTRA PARBHANI	STUDIO	TX
2.	RATNAGIRI	STUDIO	TX
3.	SANGLI	STUDIO	TX
4.	SATARA	STUDIO	TX
5.	GUJRAT RAJKOT	STUDIO	TX
6.	MADHYA PRADESH AMBIKAPUR	STUDIO	TX
7.	RAIPUR	STUDIO	TX
8.	REWA	STUDIO	TX
9.	GUNA	STUDIO	TX
10.	GWALIOR	STUDIO	MW TX
11.	GWALIOR	STUDIO	FM TX

NORTH ZONE

Sr.no	State/station	FROM	TO
1.	JAMMU & KASHMIR SRINAGAR	STUDIO	FM TX
2.	RAJASTHAN JODHPUR	FM TX	MW TX
3.	SURATGARH	STUDIO	TX
4.	NAGPUR	STUDIO	TX
5.	BIKANER	STUDIO	TX

6.	HIMACHAL PRADESH H SHIMLA	STUDIO	TV SITE (REPEATER)
7.	U.P RAMPUR	STUDIO	TX
8.	NAJIBABAD	STUDIO	TX
9.	VARANASI	STUDIO	TX

REPRESENTATIVE DIAGRAM FOR STL AT STUDIO END FOR 1+1 CONFIGURATION

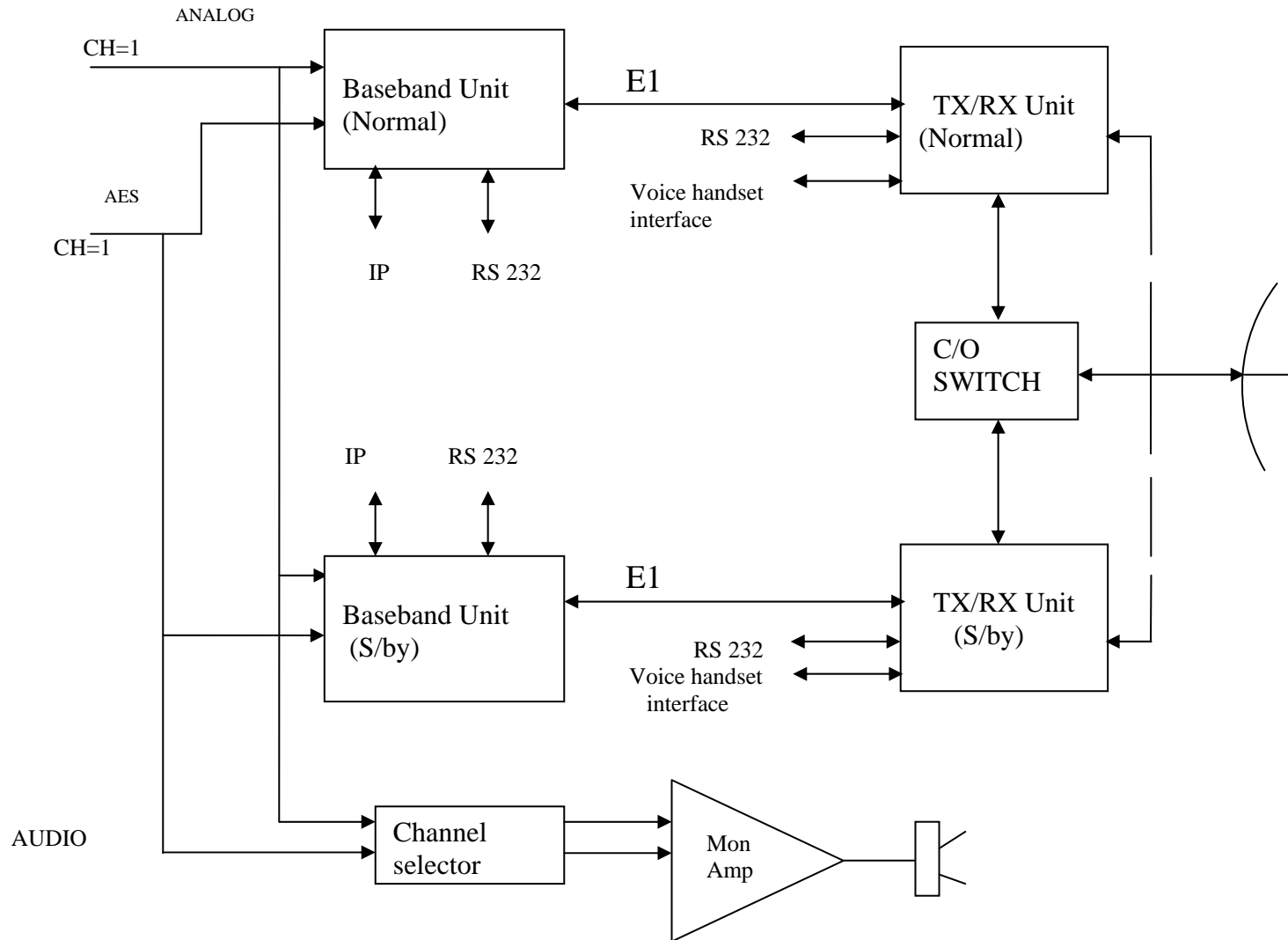

Note: Higher configurations will be similarly wired.

REPRESENTATION DIAGRAM FOR STL AT RECEIVING END FOR 1+1 CONFIGURATION

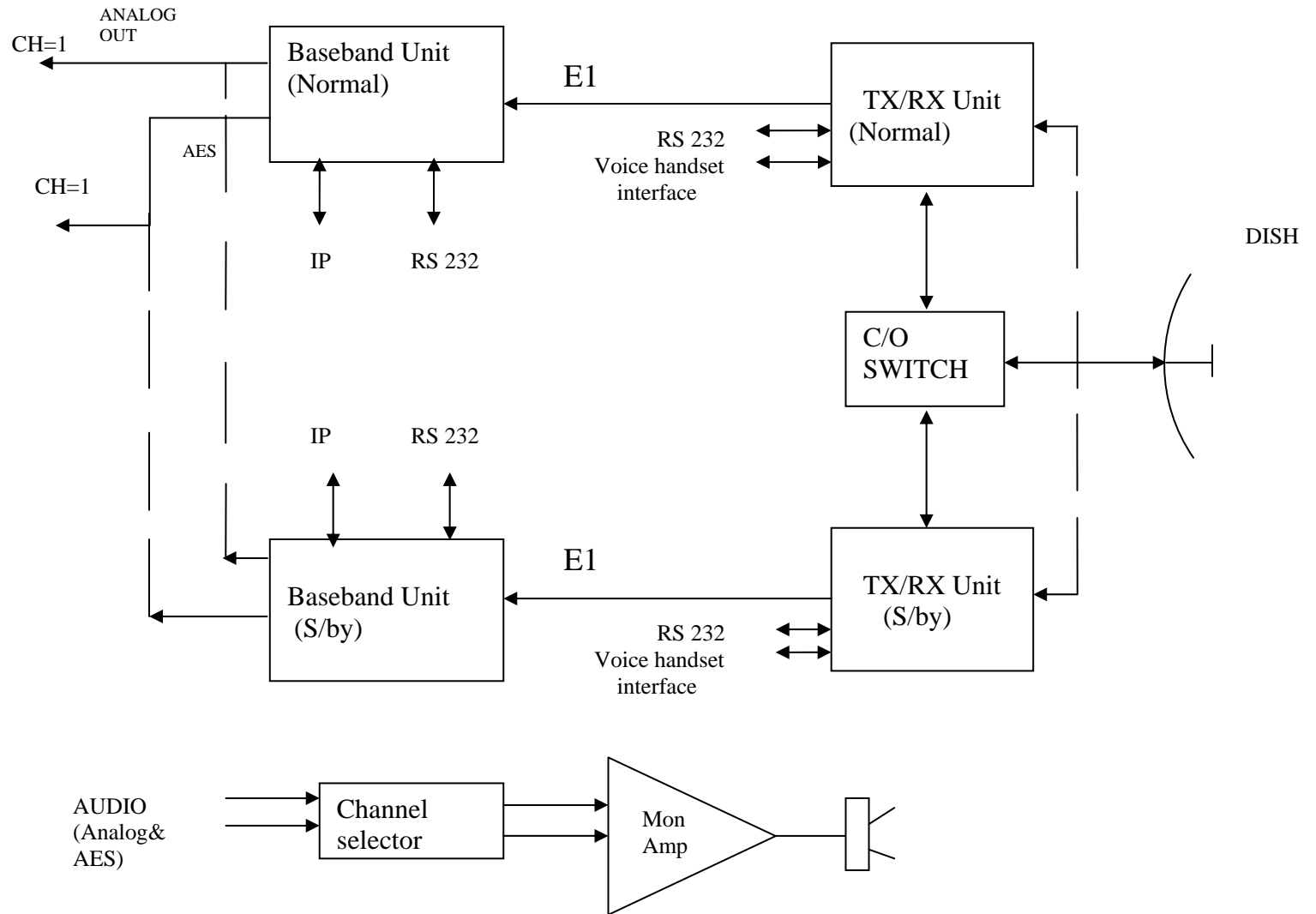

Note: Higher configurations will be similarly wired.

(ANALOG MONITORING JACKS)

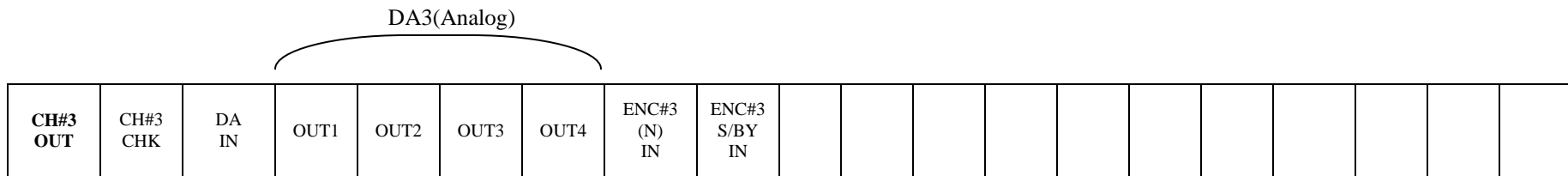
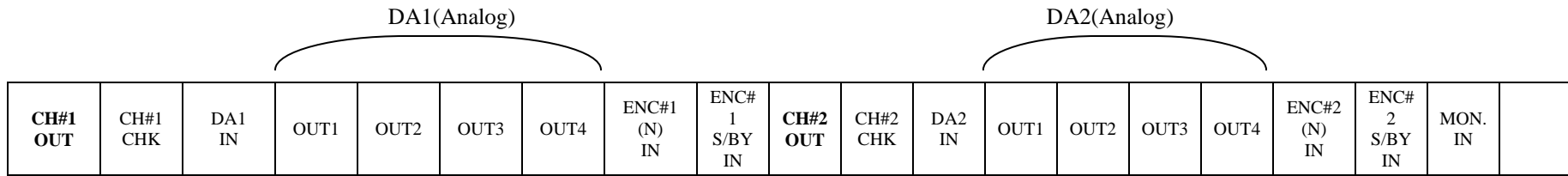

(DIGITAL MONITORING JACKS)

